

SB5

LOOSE BALLS - PALLINE SCiolTE

SB5



CE

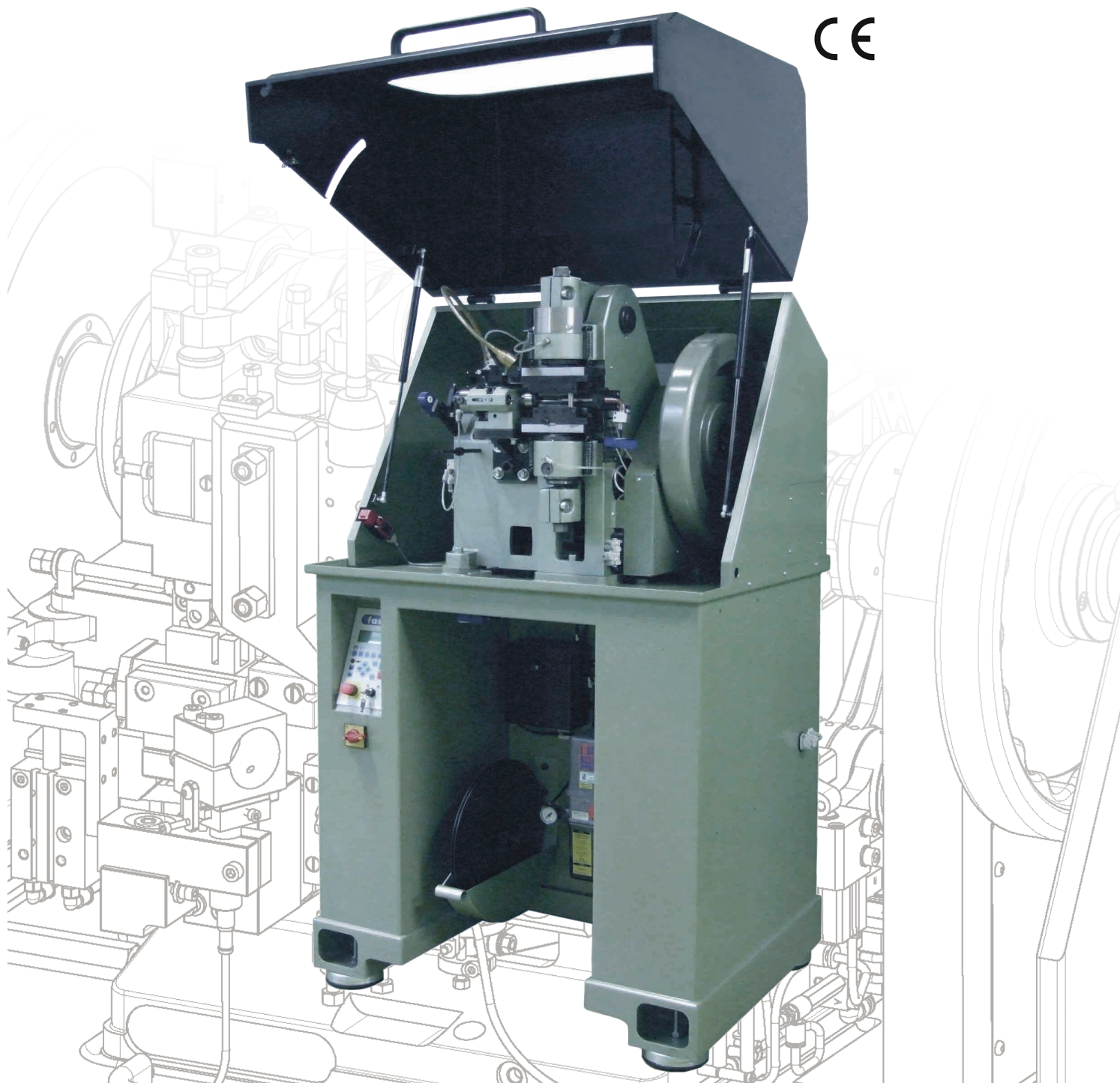

fasti

AUTOMATIC CHAIN-MAKING MACHINES & LASER SYSTEMS
MACCHINE AUTOMATICHE PER CATENA E SISTEMI LASER

fasti industriale s.p.a.

Via Polisen, 24 - 10016 Montalto Dora (TO) - ITALY
Tel. +39 0125 652 811 - Fax +39 0125 650 400

info@fasti.it

www.fasti.it

SB5

SB5 MACHINE FOR LOOSE BALLS

Machine on stand, single phase power supply, variable speed, forced lubrication, strip end and tube end sensor, ball passage sensor.

Model suitable for production of medium-small size balls, ovals, barrels from tube and strip by simply changing tools. Use of compressed air is necessary.

SB5 MACCHINA PER PALLINE SCIOLTE

Macchina su piedestallo, alimentazione monofase, velocità variabile, lubrificazione forzata, sensore fine nastro e fine tubo, sensore passaggio palline.

Modello adatto alla produzione di palline, ovaline e barilotti da tubo e da nastro di dimensioni medio piccole con il solo cambio dell'attrezzatura. È necessario l'uso dell'aria compressa.

SB5 СТАНОК ДЛЯ ПРОИЗВОДСТВА ОДИНОЧНЫХ ШАРИКОВ

Станок на станине, однофазное напряжение питания, регулировка скорости, принудительная смазка, датчик окончания проволоки и окончания трубки, датчик прохождения шариков.

Модель предназначена для производства шариков, овалов и бочек из трубки и ленты малого-среднего размера путем простой замены оснастки. Для работы станка необходим подвод сжатого воздуха.

Technical Data / Dati Tecnici

Ball dimensions Dimensioni pallina		Balls/minute Palline/minuto	Power supply Alimentazione	Max absorbed power Potenza max assorb.	Packing dimensions Dimensioni imballo	Net weight Peso netto	Gross weight Peso lordo
Ø mm		Max			cm	Kg	Kg
Min	Max						
1.80	6.00	160	230V 50Hz	400W	108 x 88 x 185	560	670

The picture shows model complete with optional groups

La fotografia rappresenta il modello nella versione completa di gruppi opzionali

All rights of modifications reserved

Ci riserviamo tutti i diritti di modifica



AUTOMATIC CHAIN-MAKING MACHINES & LASER SYSTEMS
MACCHINE AUTOMATICHE PER CATENA E SISTEMI LASER

fasti industriale s.p.a.

Via Polisen, 24 - 10016 Montalto Dora (TO) - ITALY

Tel.+39 0125 652 811 - Fax +39 0125 650 400

info@fasti.it

www.fasti.it